

VAPOUR SENSING CHARACTERISTICS OF ZNO-ZNMN₂O₄ CERAMICS USING THE VISUAL BASIC-BASED MEASUREMENT SYSTEM

Thongchai Panmatarith* and Sudarat Innoi

Received: Jun 11, 2008; Revised: May 13, 2009; Accepted: May 25, 2009

Abstract

In the present paper, ZnMnO₃ ceramics in a disk shape, synthesized by mixed oxide technique, has been investigated for NH₃, ethyl alcohol, commercial liquor, methanol, H₂O₂ and acetone vapours. Structural analysis of the ZnMnO₃ ceramics was carried out by X-ray diffraction (XRD). The XRD pattern revealed the nature of the film with a mixed phase comprising of ZnO and ZnMn₂O₄. The measurements and processing of the data was made using ADC0809, 74LS244, ET-PCI8255V3 data acquisition card, computer and Visual Basic program. The system is easy to setup and use. A visual basic program is proposed and explained in order to evaluate vapour response property. Results showed that the resistance of this sample at room temperature decreased in the presence of these vapours at 30°C in air atmosphere. The measured sensitivities to some vapours (NH₃, ethyl alcohol, commercial liquor, methanol, H₂O₂ and acetone vapours) of this sample were investigated. It is clear that this material is the most sensitive to NH₃ vapour and the least sensitive to acetone vapour. The gas sensitivity largely depends on the kind of test gas species. The sample is sensitive and selective to NH₃, ethyl alcohol and commercial liquor vapours.

Keywords: Vapour-response ceramics, ZnO-ZnMn₂O₄, Visual Basic-based measurement system

Introduction

Semiconducting oxides (SnO₂, ZnO, Fe₂O₃, TiO₂, and Ag₂O) have been found to show changes in electrical resistivity in the presence of small concentrations of certain gases. The sensing behaviour of semiconducting oxides appears to be governed by the adsorption of oxygen in the neck regions between grains. Reducing gases, if adsorbed, removed, some of the O₂- ions from the surface, releasing electrons which become

available for conduction (Moulson and Herbert, 1990). T. Nenov and S. Yordanov studies on the sensitivity of the electrical resistance of ceramic sensor materials based on ZnO, TiO₂ and SnO₂ to acetone, ethanol and ammonia are reported (Nenov and Yordanov, 1992). SnO₂ thin film gas sensors operating at room temperature were prepared with SnCl₄ as the starting material. The sensors show different electrical response in

Materials Physics Laboratory, Department of Physics, Faculty of Science, Prince of Songkla University, Hat Yai, 90112, Thailand, E-mail: tongchai.p@psu.ac.th

* Corresponding author

the detection of the vapors of ethyl alcohol at room temperature (Wang and Yang, 2006). The gaseous ammonia gas sensing characteristics of the nano-zinc oxide sensor showed high sensitivity compared to sensor fabricated with commercial zinc oxide powder (Sarala Devi *et al.*, 2006). The sensitivity to some reducing gases (acetone, ethanol, methane) of calcia doped nickel ferrite (NiFe₂O₄ + 1%CaO) and cobalt and manganese doped nickel ferrite, Ni_{0.99}Co_{0.01}Mn_xFe_{2-x}O_{4-δ} ($x = 0.01$ and 0.02), was investigated. The response time was studied, too. The gas sensitivity largely depends on the composition, temperature and the test gas species (Rezlescu *et al.*, 2006). The gas/vapour sensing studies of cobalt-doped tin oxide (Co-SnO₂) thin films performed in dry air at different temperatures in the range of 50–300°C indicated better sensing characteristics for acetone vapour (Shriram *et al.*, 2007). Pure ZnO thick films, prepared by screen-printing technique, were almost insensitive to NH₃. The Cr³⁺-activated ZnO films dipped for 5 min were observed to be sensitive and highly selective to 300 ppm of NH₃ gas at room temperature (Patil, *et al.*, 2007). Al-doped zinc oxide (ZnO) thin films were prepared by chemical spray pyrolysis technique. The sensing properties of the films towards methanol vapour are investigated for various concentrations of methanol in air at different operating temperatures in the range 200–350°C (Sahay and Nath, 2008).

A common characteristic of the mentioned data acquisition systems was the use of data loggers or microcontrollers for measuring and acquiring the signals and transmitting them to a PC through serial port RS-232 (Barney, 1988; Forero, 2006). As suggested by some author, Visual Basic-based measurement system are preferred to increase the efficiency to measurements (Patanè and Ferrari, 1997).

Descriptions on NH₃, ethyl alcohol, commercial liquor, methanol, H₂O₂ and acetone vapour sensing characteristics of ZnMnO₃ ceramics and the application of ZnMnO₃ for the vapour-sensing test using the Visual Basic-based measurement System has not been found in the literature.

In this paper, the mixed oxide method was used by us for the preparation of ZnMnO₃ sample. ZnMnO₃ ceramics in a disk shape were investigated as vapour-sensing material. We produce a Visual Basic-based measurement system to reduce the testing time for vapour response measurement. The software presented in this article was programmed to evaluate the vapour response property. The sensor elements have been tested to six vapours (NH₃, ethyl alcohol, commercial liquor, methanol, H₂O₂ and acetone vapours) at room temperature of 30°C.

Materials and Methods

The ZnMnO₃ ceramics were prepared by the mixed oxide method using reagent grade raw oxides of high purity ZnO and MnO₂ powders. Preparation sample composition was ZnO+MnO₂. The powders were weighed and mixed together in a mortar and then mixed using a mixer for 10 min. 1 wt% of an organic binder (PVA) was added and they were then pressed into cylindrical pellets. The pellets were pre-heated at 500°C (melting point of MnO₂ was 535°C) with the furnace heating rate at about 5°C/min for 1.57 h. When complete heating period, the furnace was closed and pellets naturally cooled to room temperature. These pellets were heated again at 1,100°C (for phase formation) with the furnace heating rate at about 5°C/min for 4 h. When complete heating period, the furnace was closed and pellets naturally cooled to room temperature again. The structural characterizations of the ZnMnO₃ pellets were performed on an X-ray diffractometer (PHILIPS X'Pert MPD) with Cu K α radiation.

For electric measurements, sample dimension was measured using micrometer. The opposite sites of as-heated pellets were coated with a silver paste and the components were heated at 120°C for 15 min. Experiment setup for vapour-sensing application for vapour response test with Visual Basic is shown in Figure 1. Circuit diagram for vapour-sensing test with Visual Basic are shown in Figure 2. The used sample was ZnO-ZnMn₂O₄ (Figure 3). The load resistance (R_L) is 1 M Ω . Vapour sources are NH₃, ethyl alcohol, commercial liquor,

methanol, H_2O_2 and acetone vapours (Figure 3). Form for vapour-sensing test with Visual Basic for voltage versus time of ZnO-ZnMn₂O₄ ceramics is shown in Figure 4. Code for vapour-sensing test with Visual Basic is shown in Appendix. The equipment was developed using ADC0809, 74LS244, LM555, ET-PCI 8255 card, computer and Visual Basic program commercially supplied by ETT. Co. LTD. (Organize group, 2552). When the program is started, the main menu of the Visual Basic comes to screen. Form of Visual Basic program was

created and setting the properties of Window properties were set. An electronic load was connected in series with the sample as voltage divider. This load resistor-ceramic sample voltage divider was used to supply a voltage to input of ADC0809 and sent through 74LS244 and ET-PCI8255 card and into computer. This card was used to measured the V_s and V_{L_s} signals that appeared in this voltage divider. Current from 5 V dc power supply flowed through load resistor (R_L) 1 MW and sample resistance (R_s). Voltage drop across R_s and

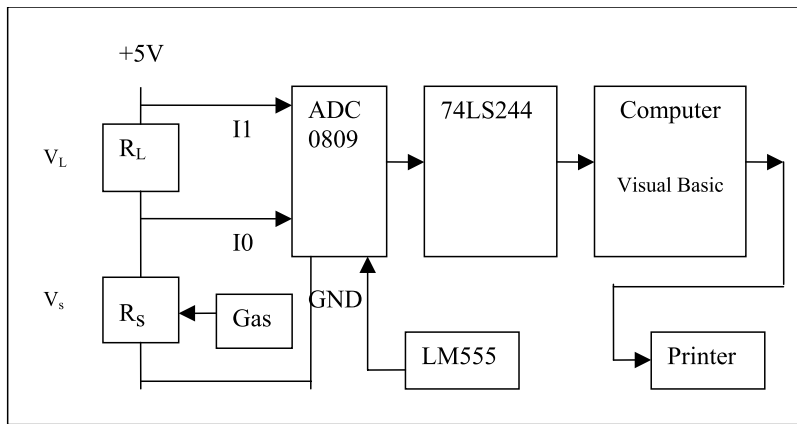

(a)

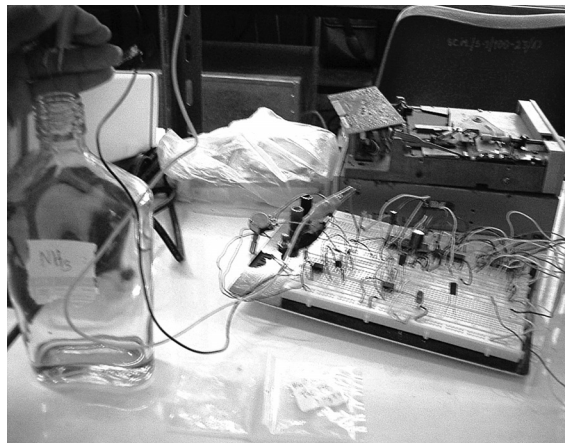

(b)

Figure 1. Experiment setup for vapour-sensing test with Visual Basic
(a) Schematic diagram
(b) photograph

R_L+R_s were V_s and V_{Ls} . Voltage V_s and V_{Ls} were transmitted to AI0 and AI1 of ADC0809, 74LS244 and ET-PCI8255 card, PCI slot and computer, respectively. Visual Basic program will works by receiving voltage V_s and V_{Ls} from LP connector and transmitted through ET-PCI8255V3 Card into computer. For

resistance determination, V_L was calculated using $V_L=V_{Ls}-V_s$. Load current (I_L) was calculated with $I_L=V_L/R_L$. Sample current (I_s) was equal to load current ($I_s=I_L$). Sample resistance (R) was calculated with $R=Vs/Is$. Resistance value (R) and resistance versus time (R vs. t) of the sample were displayed on

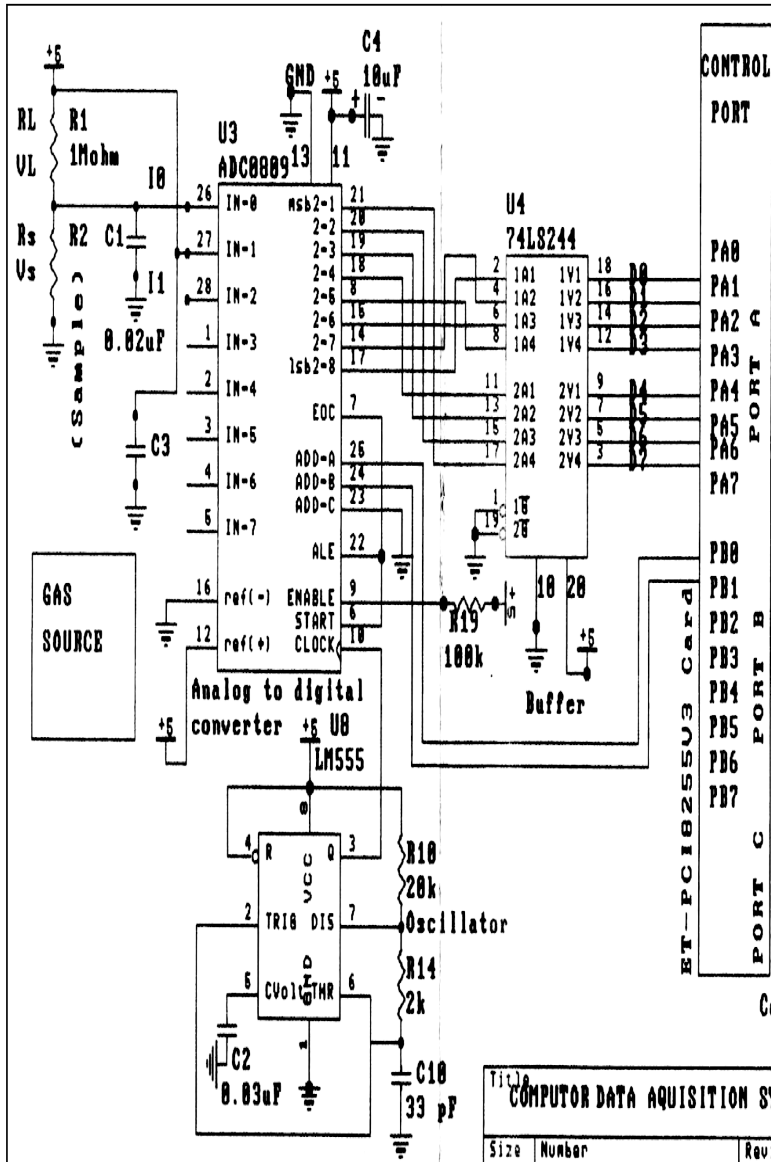

Figure 2. Circuit Diagram for vapour-sensing test with Visual Basic

computer screen. Sample was in the presence of NH_3 , ethyl alcohol, commercial liquor, methanol, H_2O_2 and acetone vapours. Program was run to show the results. Form and code were saved in computer. Form was put on working area of Microsoft words using Print Screen and printed with Printer. The computer will control the entire measurement process A gas sensitivity (S) that was defined as $S = [(R_g - R_0) / R_0] * 100$ was calculated, where R_0 was sample resistance in the absence of vapour and R_g was sample resistance in the presence of vapour. Taking into account the thermal inertia of ceramics, all measurements were carried out under the sensor thermal stabilization conditions After each exposure to gas, at a room temperature, before the beginning of a new measurement, the sensor element was stabilized before the beginning a new experiment. The measuring procedure, described above, was repeated for each sample exposed to the six test vapours, and then results was recorded.

Results and Discussion

The prepared sample was disc-shaped pellet of 4.42 mm in thickness and 11.30 mm in diameter. A X-ray diffraction pattern of the ZnMnO_3 ceramics is depicted in Figure 5. This

pattern of this ceramics, synthesized at 30°C shows two phases of ZnO and ZnMn_2O_4 .

The proposed measurement system was easy to setup with a personal computer. We used the Visual Basic 6.0 software to design the Form and code for the real-time measurement system. The results for vapour-sensing test of $\text{ZnO-ZnMn}_2\text{O}_4$ at room temperature (30°C) when exposed to a fixed amount of vapour (moving the sample into the vapour-filled bottle) was shown in Figure 4. Results showed that the resistance of this sample at room temperature decreased in the presence of vapours (Table 1 and Figure 4). A R-t characteristics indicates that a vapour response was achieved. A vapour responsivity (G) of this sample are shown in Table 1. The negative value of G showed that the resistance of this sample decreased in the presence of vapour. This sample will applied for vapour demonstrative device in the future. The observed vapour sensing characteristics of the sensor is in agreement with the results obtained by other researchers (Nenov and Yordanov, 1992; Rezlescu *et al.*, 2006; Sarala Devi *et al.*, 2006; Wang, 2006; Patil *et al.*, 2007; Sun, 2007; Sahay, 2008). The response and recovery times of the sample are shown in Table 1. The response and recovery times are found to be dependent on the kinds of vapour sources.

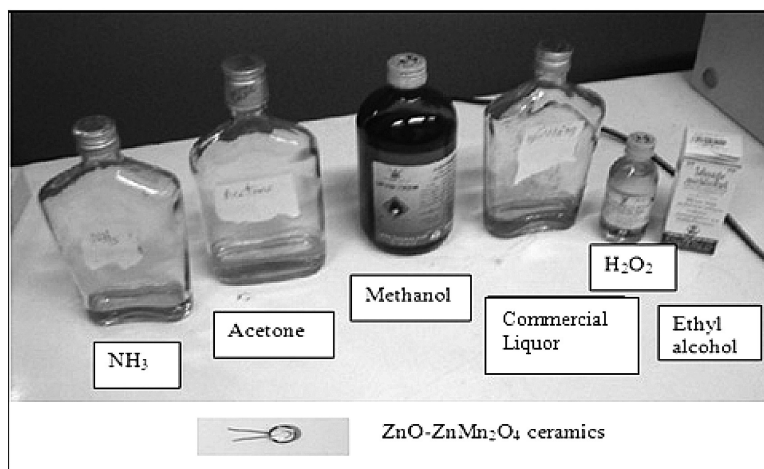

Figure 3. Vapour sources and $\text{ZnO-ZnMn}_2\text{O}_4$ sample

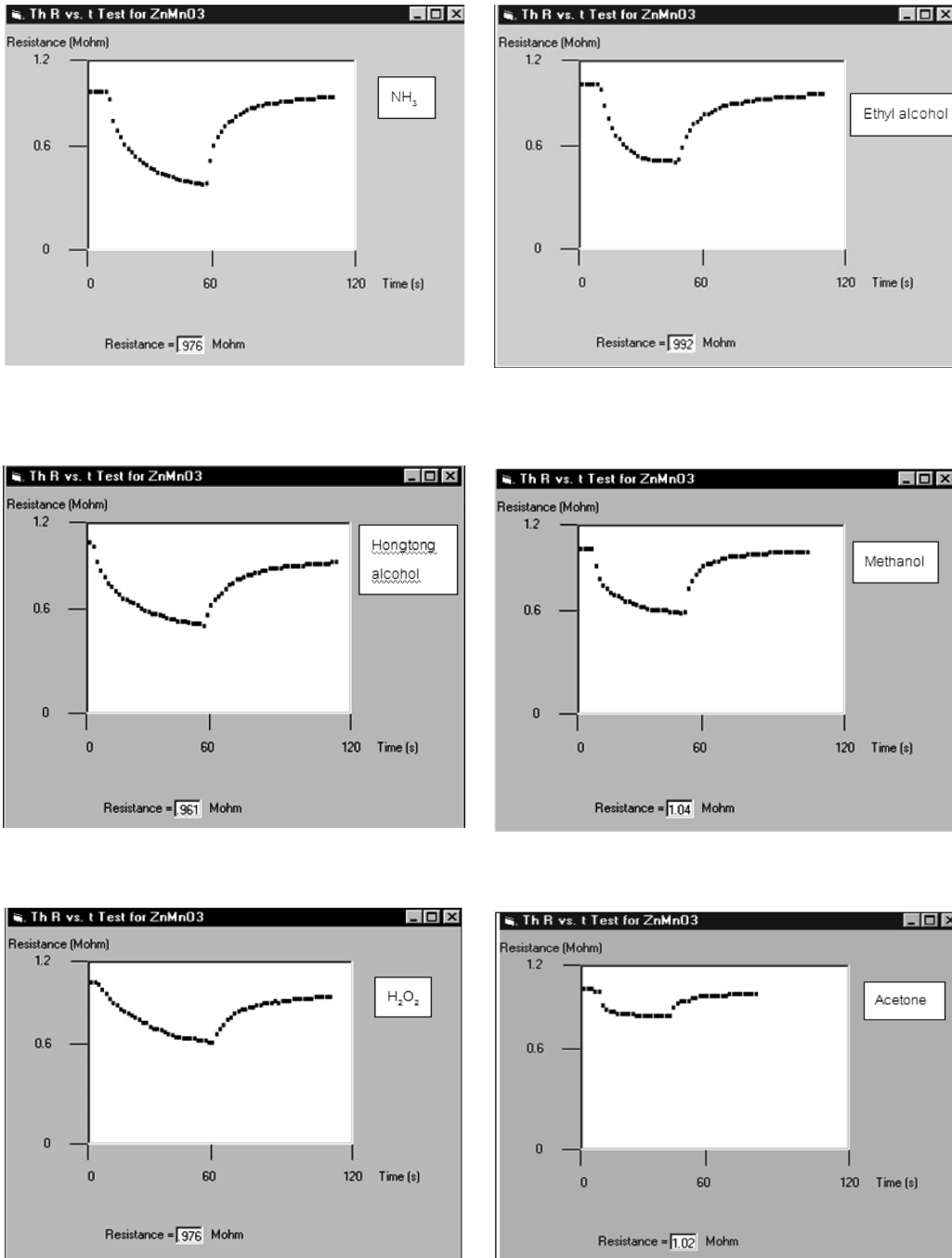

Figure 4. Voltage versus time of ZnMnO₃ ceramics for vapour-sensing test. (NH₃, ethyl alcohol, commercial liquor, methanol, H₂O₂ and acetone)

Gas sensitivity (arranged from maximum to minimum)

$\text{NH}_3 > \text{ethyl alcohol} > \text{commercial liquor} > \text{methanol} > \text{H}_2\text{O}_2 > \text{acetone}$

Response time (arranged from minimum to maximum)

$\text{acetone} < \text{ethyl alcohol} < \text{methanol} < \text{NH}_3 < \text{commercial liquor}, \text{H}_2\text{O}_2$

Recovery time (arranged from minimum to maximum)

$\text{Acetone} < \text{ethyl alcohol} < \text{methanol} \ll \text{NH}_3 < \text{commercial liquor}, \text{H}_2\text{O}_2$

It is clear that this material is the most sensitive to NH_3 vapour and the least sensitive to acetone vapour. The sensitivity of this compound to gas can be explained by the involvement of a possible reaction of gas with the sample surface, leading to an decrease of sample resistance. The sensing behaviour of semiconducting oxides appears to be governed by the adsorption of oxygen in the neck regions between grains. Reducing gases, if adsorbed, removed, some of the O_2^- ions from the surface, releasing electrons which become available for conduction (Moulson and Herbert, 1990).

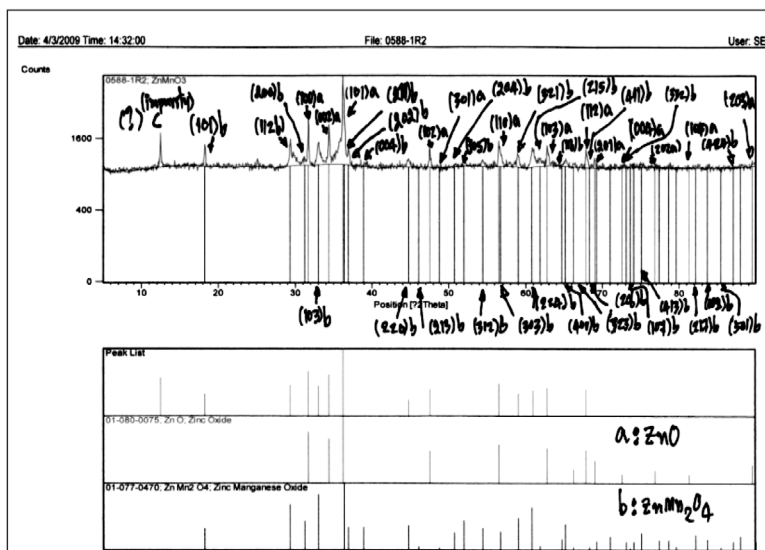

Figure 5. XRD pattern at room temperature for ZnO-ZnMn₂O₄ ceramics

Table 1. Sensitivity of ZnO-ZnMn₂O₄ at room temperature 30°C to various vapours

Kinds of gas	R _g (MΩ)	R _a (MΩ)	S (%)	t _{res} (s)	t _{rec} (s)	Order by S
NH ₃	0.43	1.01	-57.43	45.65	52.17	1
ethyl alcohol	0.52	1.07	-51.40	35.29	42.35	2
commercial liquor	0.55	1.08	-49.07	53.33	53.33	3
methanol	0.65	1.03	-36.89	43.29	49.48	4
H ₂ O ₂	0.69	1.05	-34.35	53.33	53.33	5
Acetone	0.84	1.00	-16.00	11.43	14.29	6

Conclusions

The ZnMnO₃ ceramic pellets fabricated by mixed oxide techniques are in disc-shaped form. XRD pattern shows two phases of ZnO and ZnMn₂O₄. The studies of the sensitivity to six kinds of vapours (NH₃, ethyl alcohol, commercial liquor, methanol, H₂O₂ and acetone vapours) are carried out on this sample. The Visual Basic-based measurement system for monitoring the gas response test has been prepared using a procedure based on ADC0809, 74LS244, ET-PCI8255 card, computer and Visual Basic program. This pellet exhibited vapour response. Result showed that the resistance of this sample at room temperature decreased in the presence of vapours (Table 1). This result signify the application potential of this pellets for vapour detection. The main conclusion from these results is that the interaction of the Mn doped ferrites with gases is a more complicated mechanism including the removal of lattice oxygen, modification of the oxidation state and creation of new bonds between native and dopant ions (Rezlescu, *et al.*, 2006). This experimental work was carried out at the Physics department, Faculty of Science, Prince of Songkla University, Thailand. The ET-PCI8255V3 card was purchased from ETT. Co. Ltd, Thailand. The program was successfully tested with a dataset and the results are presented. We have developed a sensor based on ZnO-ZnMn₂O₄ pellets to detect vapours. Further studies are necessary to apply this sample for operation of vapour switch device.

Acknowledgements

This work was supported by Prince of Songkla University, Thailand. We are grateful to the reviewers for useful comments.

Appendix

Code for vapour-sensing test with Visual Basic

```
'Vapour response test
'Lab name
Private Declare Function Inp Lib "inout32.dll"
```

```
Alias "Inp32" (ByVal PortAddress As Integer)
As Integer
Private Declare Sub Out Lib "inout32.dll" Alias
"Out32" (ByVal PortAddress As Integer, By
Val Value As Integer)
'setting the input-output operation

Private Sub Form_Load() Out &H14CC,
&H90Left = (Screen.Width - Width) / 2
'setting control word
'defined the position of displayed
Form on screen
Top = (Screen.Height - Height) / 2
End Sub

Private Sub Timer1_Timer()
Picture1.Cls
'clear screen
For i = 20 To 3500 Step 50 Out &H14C4,
&H0
'repeat operation
'Io, setting for Vs entering to input 0 of
port A active
Call delay
Vs = Inp(&H14C0) Out &H14C4, &H1
'V, voltage into Io of port A
'I1, setting for VLs entering to input 1 of
port A active
Call delay
VLs = Inp(&H14C0)
'voltage into Io of port A
VL = VLs - Vs
'V, calculate the VL value
RL = 1
'1 Mohm ; setting the load resistance value
IL = (VL / RL)
'uA, Is=IL ; calculate the load current
R = (Vs / IL)
'Mohm ; calculate the load resistance
LabelR.Caption = R
'display the sample resistance on computer
screen
x = i
'defining the x-coordinate
y = 255 - (255 / 1.2) * R
'defining the y-coordinate

Picture1.PSet (x, 10 * y), vbBlack
'displaying the R vs. t curve
```



```

Next i
End Sub

Sub delay()
For i = 1 To 600
    'time-delaying treatment
DoEvents
Label8.Caption = Timer
Next i
End Sub

```

References

- Barney, G.C. (1988). *Intelligence Instrumentation : Microprocessor Applications in Measurement and Control*. 2nd, Prentice Hall, NY, 467p.
- Patanè, D. and Ferrari, F. (1997). Seismpol a visual-basic computer program for interactive and automatic earthquake waveform analysis. *Comput. Geosci-UK.*, 23(9):1,005-1,012.
- Forero, N.G. (2006). Development of a monitoring system for a PV solar plant. *Energ. Convers. Manage.*, 47(15-16): 2,329-2,336.
- Moulson, A.J. and Herbert, J.M. (1990). *Electroceramics*. Chapman & Hall, London, 464p.
- Nenov, T. and Yordanov, S. (1992). Ceramic sensor device materials. *Sensor. Actuat. B-Chem.*, 8(1):117-122.
- Organizer group. (2550). ET-PCI8255V3 Card user manual and CD diskette. ETT Co., LTD, Bangkok.
- Patil, D.R., Patil, L.A., and Patil, P.P. (2007). Cr₂O₃-activated ZnO thick film resistors for ammonia gas sensing operable at room temperature. *Sensor. Actuat. B-Chem.*, 126(2):368-374.
- Rezlescu, N., Iftimie, N., Rezlescu, E., Doroftei, C., and Popa, P.D. (2006). Semiconducting gas sensor for acetone based on the fine grained nickel Ferrite. *Sensor. Actuat. B-Chem.*, 114(1):427-432.
- Sahay, P.P. and Nath, R.K. (2008). Al-doped ZnO thin films as methanol Sensor. *Sensor. Actuat. B-Chem.*, 134(2):654-659.
- Sarala Devi, G., Bala Subrahmanyam, V., Gadkari, S.C., and Gupta, S.K. (2006). NH₃ gas sensing properties of nanocrystalline ZnO based thick films. *Anal. Chim. Acta.*, 568(1-2):41-46.
- Shriram, B., Patil, P.P., Patil and Mahendra, A. More. (2007). Acetone vapour sensing characteristics of cobalt-doped SnO₂ thin films. *Sensor. Actuat. B-Chem.*, 125(1):126-130.
- Wang, H.C. and Yang, M.J. (2006). Fast response thin film SnO₂ gas sensors operating at room temperature. *Sensor. Actuat. B-Chem.*, 119(2) : 380-383.
- Sun, Z. (2007). Simple synthesis of CuFe₂O₄ nanoparticles as gas-sensing materials. *Sensor. Actuat. B-Chem.*, 125(1):144-148.

